

Start a DNA diagnostic service

K F Kelly, N E Haites, A W Johnston

In 1985 the Scottish Home and Health Department allocated funds under the New Developments in Health Care Programme to establish a national molecular genetics diagnostic service with laboratories in four university cities: Glasgow, Edinburgh, Dundee, and Aberdeen. Each centre would be responsible for the diagnosis of certain diseases for the whole of Scotland, and centres would cooperate by collecting blood and extracting DNA and dispatching it to one of the laboratories for analysis. Each centre would be responsible for counselling and investigating patients in their areas. The laboratories would thus act as a consortium with considerable contact and cooperation, sharing work, and avoiding expensive duplication of services.

The disorders to be diagnosed were allocated in a way that reflected a research or clinical interest that already existed—for example, X linked muscular dystrophies to Glasgow. Other diseases allocated were cystic fibrosis and Huntington's disease to Edinburgh, dystrophia myotonica to Aberdeen, and adult polycystic kidney disease to Dundee.

Our laboratory is associated with the Cytogenetics Service, which covers the whole Grampian region. In this brief description of the first two years our service has operated we include practical advice on setting up a molecular genetics service.

Our primary aim was to establish the necessary laboratory procedures and to acquire the probes needed to fulfil our commitment. About 100 blood samples from patients affected by various diseases, notably Huntington's disease and muscular dystrophies, had already been stored by the clinical geneticists before the laboratory was established. We were therefore quickly able to provide DNA from families with muscular dystrophy for analysis in Glasgow. Soon after work started and probes became available clinicians began sending in blood samples from families. Table I shows some of the disorders for which we have been asked to prepare DNA, with the numbers of samples for 1986 and 1987. Several local families were known to have dystrophia myotonica, so this disease was used to test the development of our laboratory techniques. The probes that we now have which proved useful in the diagnosis of dystrophia myotonica were donated by research laboratories in the United Kingdom and The Netherlands.

Laboratory service

Staffing—A postdoctoral scientist with five years' experience in molecular biology and a graduate technician are in charge of our laboratory. Another technician will soon be required. We believe that at least two scientists are needed to provide an effective core group.

Accommodation—The molecular genetics service was allocated a small office and a laboratory (36.5 m²) which is adequate for preparing DNA, restriction analysis, and gel electrophoresis. Additional laboratory space is required for the microbiological and isotope work necessary for preparing probes.

Equipment—In the first year basic equipment was obtained for our exclusive use. In addition to bench top

centrifuges a versatile centrifuge such as the Sorvall RC5C is invaluable for preparing probes and genomic DNA. For restriction analysis it is necessary to have microcentrifuges, a set of micropipettes, and variable temperature waterbaths for digests and hybridisations. Two powerpacks are needed with three or four gel tanks, one being of the "baby gel" type for probe sequence isolation. Such basic equipment might cost about £15 000. Automated DNA extraction should allow a much larger sample load to be handled at an additional cost of about £30 000. Table II lists the basic equipment required in a molecular genetics diagnostic laboratory. The annual running costs, based on our

TABLE I—Sample intake for 1986 and 1987 (numbers given) in Aberdeen, showing some of the principal disorders and diagnostic centres in Scotland

Disorder	1986	1987	Analysis possible	Centre
Huntington's disease	93	54	Yes	Edinburgh
Duchenne muscular dystrophy	33	18	Yes	Glasgow
Becker muscular dystrophy	0	9	Yes	Glasgow
Dystrophia myotonica	12	63	Yes	Aberdeen
Cystic fibrosis	5	19	Yes	Edinburgh
Adult polycystic kidney disease	0	14	Yes	Dundee
Fragile X	6	18	Not yet	Aberdeen
Hypercholesterolaemia	0	16	Yes	Aberdeen
Others	65	165		

Note: The 1987 figures represent the intake up to December 1987.

TABLE II—Basic equipment required in a molecular genetics laboratory

- 1 Bacteriology facilities for probe propagation and preparation—for example, an incubator where cultures can be grown
- 2 Preparative, benchtop, and microcentrifuges are necessary for plasmid isolation, DNA preparation, and handling the very small volumes of solution in restriction digestion procedures
- 3 Gilson type micropipettes are essential for restriction digestions, probe labelling, and many other purposes
- 4 Variable temperature waterbaths are required for restriction digestions and hybridisation procedures
- 5 Electrophoresis equipment should include at least two powerpacks with gel beds of various sizes. Many types are available (BRL, Pharmacia/LKB)
- 6 Darkroom facilities should include an ultraviolet light source and camera to record the appearance of gels, and x ray cassettes are necessary for autoradiography
- 7 Fridges and freezers are required to store samples and chemicals such as DNA and restriction enzymes, a minimum requirement would be a -20°C freezer and a -70°C freezer.

Note: This list is not comprehensive, but these items would be required for the exclusive use of a diagnostic service. Absolute numbers depend on finance available to equip a new laboratory. Consideration should be given to laboratory space, which is required for microbiology (probe preparation) and isotope handling and disposal. Separate rooms are ideal.

figures and covering isotope, enzymes, hybridisation membranes, and chemicals, would be about £6000-7000.

Methods—Practical experience has to be acquired before reliable techniques can be established. We found valuable the descriptions in the publications cited in table III, where the necessary details for all the techniques are given.

DNA probes—To obtain many probes it is necessary to write directly to the originator, but requests for diagnostic use are rarely refused. Some probes may be obtained from the American Type Culture Collection, Rockville, Maryland, for about \$50 each. The name of a laboratory staff member must be sent to the ATCC

Medical Genetics Laboratories, Department of Genetics and Microbiology, University of Aberdeen, Medical School, Aberdeen
 K F Kelly, PHD, molecular geneticist
 N E Haites, MB, lecturer in clinical genetics
 A W Johnston, FRCP, consultant physician
 Correspondence to: Dr A W Johnston, Woodend General Hospital, Aberdeen AB9 2YS.

before they will accept an order from their catalogue. Many probes are obtained as plasmids in bacterial hosts so permanent stocks have to be established, genotypes tested, and amplified probe DNA made. Good microbial practices are essential at this early stage so that valuable probe stocks are not contaminated.

TABLE III—Publications and basic techniques which are practically useful

Useful publications:
Maniatis T, et al. *Molecular cloning, a laboratory manual*. Cold Spring Harbor, New York: Cold Spring Harbor Laboratory Press, 1982
The Practical Approach Series. IRL Press, Oxford (especially Davies KE. *Human genetic diseases*, 1986)

DNA extraction methods:
Kunkel L, et al. Whole blood. *Proc Natl Acad Sci USA* 1977;74:1254
Old J. Chorion villus. In: Davies KE, ed. *Human genetic diseases*. Oxford: IRL Press, 1986

Restriction enzyme digestion of genomic DNA:
4-5 µg of DNA with 20-25 units of enzyme in a total volume of 30 µl.
Incubate for 5 hours or overnight. Follow manufacturers' instructions for buffer compositions

Labelling of DNA:
Oligolabelling is efficient and simple. Kits are available commercially or nucleotide mixes can be prepared in the laboratory: both work well.
Klenow enzyme is required. Feinberg A P, Vogelstein B. *Anal Biochem* 1984;137:266

Hybridisation membranes:
We have found Hybond-N and GeneScreen Plus (Amersham and NEN) satisfactory. In the prehybridisation and hybridisation solutions BSA can be replaced with powdered milk to give good blocking

Autoradiography:
We use commercially available cassettes with two intensifying screens and standard x ray film. Exposure is for 2-3 days at -70°C

Preparation of genomic DNA—Preparing genomic DNA from blood and tissue by the method of Kunkel et al (table III) has proved perfectly satisfactory. For cleaning up the DNA after proteinase digestion we use redistilled phenol, available commercially, rather than impure grades which may affect restriction enzyme activity. Digestion of genomic DNA carried out overnight using four to fivefold excess of enzyme (1 µg DNA to 4-5 units of enzyme) normally works well. It is important that digestion goes to completion to avoid misdiagnoses owing to the presence of the products of partial digestion. DNA can be stored in TE buffer at 4°, -20°, or -70°C in 1.5 ml Eppendorf type tubes.

Hybridisation methods—In a laboratory starting up from scratch hybridisation may cause the most problems. We found that the main difficulties arose in labelling the probe DNA and in achieving good hybridisation signals free from background contamination. Except in one or two special cases, such as minisatellite repeat probes, the best method for labelling probes is the random oligonucleotide priming technique of Feinberg and Vogelstein (table III). This requires that isolated probe sequence is prepared on a low melting point agarose gel, but very small amounts of probe DNA can be labelled efficiently by this method. Of the many methods and types of filter material available, we have used and obtained good results with the nylon membranes Hybond and GeneScreen Plus. Before experimenting with other hybridisation methods it is wise in the first instance simply to follow the manufacturer's instructions. Although the methods may not be the most rapid, they are well tested and reliable. Southern blotting itself rarely poses problems, but inefficient prehybridisation (the process which blocks membrane sites, thus reducing non-specific probe binding) may do. Care is required here and in the preparation of pure probe to ensure that no non-probe sequences are labelled. We are currently testing a blot processor system for diagnostic use. In this system special bags are provided that have stoppered ports through which solutions can be added and removed. By attaching a pump, filters can be washed rapidly and efficiently and the special holding apparatus cuts down the operator's exposure to radioactivity.

Practical problems—Although the laboratory staff were experienced in the techniques of restriction digestion, Southern blotting, and hybridisation, some problems were encountered, particularly in the hybridisation steps, which caused considerable frustration. Usually there was no clear reason why an analysis would fail, but about nine months were spent testing out membrane samples and prehybridisation, hybridisation, and labelling conditions until methods suitable and robust enough for use were developed. Problems in the setting up stages in new laboratories are not uncommon and should be expected.

Procedure time—We now expect to be able to produce a result—that is, identify a marker for the disease if it is present—within 10-12 days of receiving a blood sample (assuming that no technical problems occur and that we have the correct probes). Analyses are not undertaken until samples are available from appropriate family members.

Clinical considerations

While the clinical geneticists were delighted to make use of the consortium to improve the service to the patients attending the genetic clinic in Aberdeen, several hurdles needed to be overcome to make efficient use of its facilities. One was the need to have other clinicians educated to understand how current molecular biology techniques could be used to keep this information updated—no mean feat in a discipline where rapid progress is being made.

Another is the need to carry out extended family studies to obtain the maximum information from DNA analysis. Many probes do not detect the exact location of the affected gene but detect sequences that are sufficiently close on the chromosome that they have a high probability of being inherited with that gene (they are therefore known as linked probes). Family studies are essential so that the marker patterns (restriction fragment length polymorphisms or RFLPs) from both affected and unaffected members can be identified—that is, the family made informative. Since in this form of analysis it is rarely possible to do individual tests, we have sought cooperation from physicians, paediatricians, ophthalmologists, general practitioners, and others. It has also been necessary to contact doctors in other parts of Scotland to speak to a family and where possible obtain blood. Blood samples to make a local family informative have arrived from as far afield as the United States.

Difficulties may also arise in explaining to the referred members of the family the reason why other members have to be involved and, to them, why they, who are often unaffected or spouses, need to give blood. Remarkably, most members of families seem to be delighted to be involved for the good of a few. But because of fear of the unknown or a family disagreement some have refused. This type of clinical work is extremely time consuming. For each family group several consultations are required to ensure that all members of the family are fully informed and have understood the nature of the test, the results it may produce, and especially the limitations of the analysis. Once results are available for a family further counselling is required to discuss the implications for each member.

For the dystrophia myotonica families studied so far our results have confirmed the unaffected state of many individuals at high risk of carrying the abnormal gene and established the affected state of some whose signs were so slight—early cataracts and slight electro-myographic changes—that the diagnosis could easily be overlooked. Several family groups have now been made informative for prenatal diagnosis. This is of particular relevance to women who, even when mildly

affected, may have children with a severe form of this disease which may result in neonatal death. Figure 1 shows a pedigree from a family informative with the linked probe APOC2 in a two polymorphism analysis.

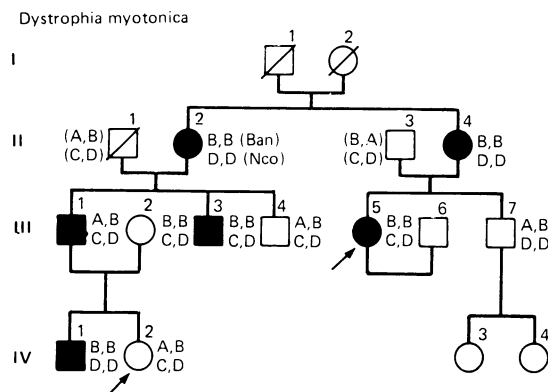

FIG 1—Pedigree of a family with dystrophia myotonica. The condition is segregating with haplotype B, D, and the clinically normal propositus IV-2 has a 96% chance of having inherited the normal gene. Propositus III-5 could be informative for prenatal diagnosis

In another autosomal dominant condition, familial hypercholesterolaemia, the diagnosis can be made in children before abnormal lipid profiles are noted. This allows dietary control before incorrect eating habits are acquired. Figure 2 shows a pedigree where this condition was identified in a young child by means of restriction fragment length polymorphism analysis using part of the low density lipoprotein receptor gene as a probe. In the past year results from other members of the consortium have contributed to the management of families in the Aberdeen area with individuals suffering from inherited diseases such as Duchenne muscular dystrophy, cystic fibrosis, and adult polycystic kidney disease.

Discussion

We think it is essential that in addition to laboratory facilities for diagnosing genetic disorders there is also sufficient clinical support. When prenatal diagnosis is being considered the whole family should be investigated in the genetic clinic before another pregnancy is considered to ensure that an informative polymorphism is available for that family. Similarly, if the disease cannot be investigated by the laboratory another unit must be approached or the necessary probes obtained and prepared, otherwise there may be undue haste or delay, or both. In identifying families who require the service of a molecular genetics laboratory the cooperation of many people, particularly the family doctors, is of great importance. The ability to provide advice rapidly to anxious families depends on the closest liaison between the DNA laboratory and the clinical geneticist. This is greatly facilitated by the medical and laboratory staff being located close together, so that the best possible approach to diagnosis for a particular family can be easily discussed.

The numbers of families identified and tested for a particular disorder in a region will reach a peak and then decline to a much lower level. This process will be repeated as it becomes possible to diagnose more disorders, producing an increasing number of family groups for whom DNA testing is of diagnostic value. Once families have been tested with informative probes, then only the children born subsequently will require investigation so that a plateau in sample numbers will eventually be reached. It will be necessary to provide a safe repository for DNA samples, which may perhaps be stored for several generations, so that improved analysis can be carried out as new probes are

developed. There are now probes available for use in about 20 serious diseases (covering nearly two thirds of the important single gene defects) any of which we might be asked to investigate.¹⁻⁴ Looking just at Huntington's disease, for which we now have 147 samples stored, in the Grampian region alone there are another 400-500 people who might require testing. There is a great deal of work for a molecular genetics laboratory, and we estimate that our present staff could cope with about 500 samples a year.

It is necessary to add to the range of probes maintained as research makes new cloned sequences available, but this also complicates estimates of costs. At present, a four probe, six polymorphism analysis of eight people might require consumables worth around £95 (estimated on the unit cost of enzyme, isotope, and hybridisation membrane), but mostly costs will vary depending on the sample load and the need to replace consumable materials. The time (10-12 days) taken to complete an analysis would be typical for other laboratories offering this kind of service.

For Aberdeen the consortium arrangement works well through cooperation and regular contact among staff in the four centres. Similar arrangements could undoubtedly be made in other areas so that expense was kept as low as possible, while allowing centres to develop skill in diagnosing a particular group of disorders. In Aberdeen introducing a molecular genetics laboratory has improved the service for patients and encouraged many new research initiatives of potential diagnostic value.

As the workload expands further problems will occur. Despite the experience of staff it may take a long time to convert research techniques into routine diagnostic use, although dedicated training courses could shorten this period. Inevitably, the priorities of the molecular genetics service will have to be determined, but cost benefit analysis of the existing molecular genetics service has already shown its value in patient care.⁵ In the early years at least the numbers of medical and scientific staff may have to be increased with the growing number of disorders which can be analysed and as the families who are affected by genetic disease become aware of the power of the new technology.

We thank Professor W J Harris of the department of genetics and microbiology for comments and additions to this article.

- 1 Weatherall D. Molecular and cell biology in clinical medicine: introduction. *Br Med J* 1987;295:587-9.
- 2 Pembrey M. Impact of molecular biology on clinical genetics. *Br Med J* 1987;295:711-3.
- 3 Cooper DN, Schmidtke J. Diagnosis of genetic disease using recombinant DNA. *Hum Genet* 1986;73:1-11.
- 4 Cooper DN, Schmidtke J. Diagnosis of genetic disease using recombinant DNA. *Hum Genet* 1987;77(suppl):66-75.
- 5 Chapple JC, Dale R, Evans BG. The new genetics: will it pay its way? *Lancet* 1987;i:1189-92.

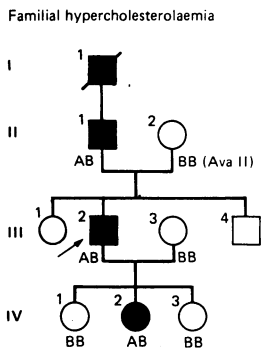

FIG 2—Pedigree of a family with familial hypercholesterolaemia. The condition is segregating with the paternal A allele, and thus IV-2 has a high risk of being affected

ANY QUESTIONS

A man in his 70s with the restless legs syndrome benefited from Sinemet. Is long term treatment with this drug safe in a person who does not suffer from Parkinson's disease?

I am not aware of any trials that show benefit from Sinemet or other dopa analogues in treating the restless legs syndrome. This group of drugs is best confined to patients with parkinsonism. The careful and selective use of clonazepam and of certain synthetic opioids is generally effective in the symptomatic control of Ekbohm's syndrome of restless legs and they do not have the potential hazards of long term treatment with Sinemet.—J M S PEARCE, consultant neurologist, Hull.